



Hobson Engineering Co. Pty. Ltd

A.B.N. 38 000 289 958

Quality Fasteners Since 1935

Sydney

14 Victoria Ave
Castle Hill NSW 2154

Ph: (02) 8853 2233

Fax: (02) 9899 5551

email: salesnsw@hobson.com.au

Brisbane

62 Murdoch Circuit
Acacia Ridge Qld 4110

Ph: (07) 3711 9766

Fax: (07) 3711 4551

email: salesqld@hobson.com.au

Melbourne

Unit 1 155 Abbots Road
Dandenong South Vic 3175

Ph: (03) 9797 3333

Fax: (03) 9799 3081

email: salesvic@hobson.com.au

Perth

284 Victoria Road
Malaga WA 6090

Ph: (08) 9248 8077

Fax: (08) 9248 8085

email: saleswa@hobson.com.au

Perth

Unit 1 Purdy Place
Canning Vale WA 6155

Ph: (08) 9456 0777

Fax: (08) 9455 5491

email: saleswa@hobson.com.au

Tasmania Agent

R.M. Daniels & Co P/L
29 Mornington Road

Mornington Tas 7018

Ph: (03) 6244 7455

Fax: (03) 6244 7317

www.hobson.com.au



SQUIRTER™ DTIS the best way to bolt!

Top



Base

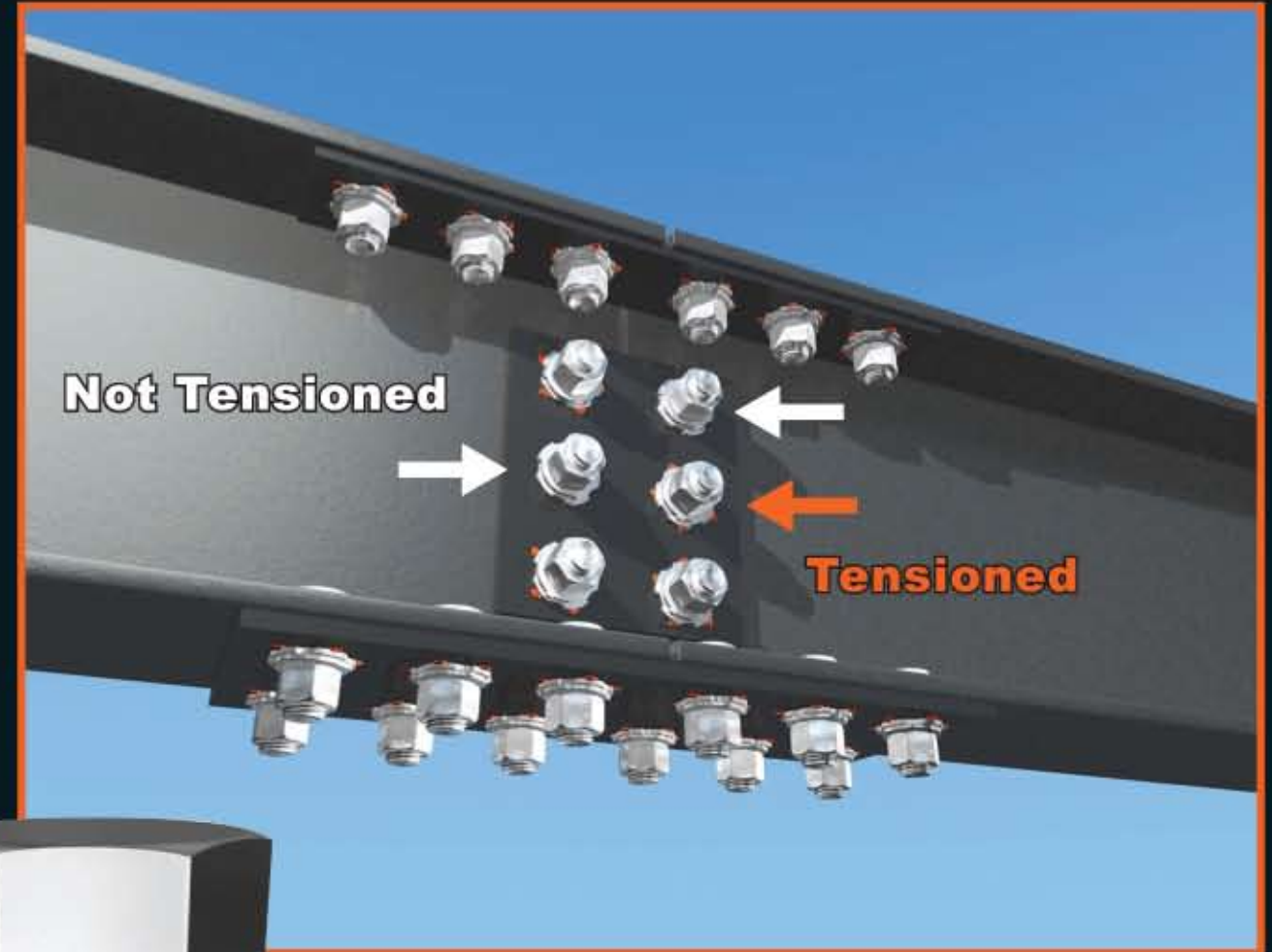

orange is good

Since 1935

... because quality matters



Get orange and you've got it right!

Demystifying the tensioned 8.8 bolt myth *'If it's torqued, it's tight!'*

Torque is the twisting force it takes to spin a nut along the threads of a bolt. You can build up plenty of torque while installing a bolt and never actually tighten it successfully. This torque build-up can be caused by many different factors common to jobsites; dirt, dust, heat, rust, rain, condensation, poor storage, damaged threads, and poor lubrication. Or a wrench not being able to deliver enough torqueing power. You may think that driving bolts to a certain torque may be the best way to bolt... What you'll find..... is a lot of loose bolts.

TENSION is the goal of bolting.

Tension is produced by stretching the bolt. You want tension because bolt stretch draws up the beams, clamping them together... Tension is the goal of bolting. It's the tension in the bolt that clamps the steel beams together. With tension in mind...Direct Tension Indicators were created. This type of flat washer is manufactured with bumps on the top. Whether you use it under the head or on the nut end, the goal is to crush the bumps. The bumps will not crush unless the bolt has been TENSIONED, no matter how much torque is applied. Once the bumps have been crushed, inspection is with a feeler gage. When using SQUIRTER™ DTI's (Direct Tension Indicator), once calibrated, bump compression can be gauged by the volume of squirt without a feeler gage.

The best way to bolt is now ... SQUIRTER™DTI's

This is a SQUIRTER™ DTI. It has all of the same specifications as a regular DTI. In addition, under each bump is cured orange silicone with a channel leading to the outer diameter. When the bumps are compressed, the silicone squirts out through the channel. Check out the bolts on the structure below. Just by looking, you can tell which bolts are tensioned, which ones are not, and why. It's that simple!

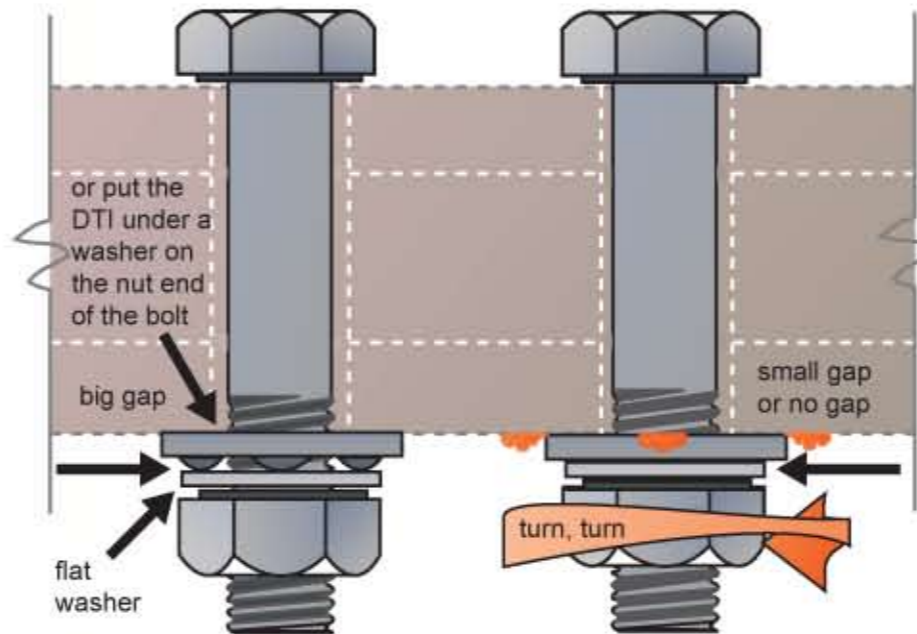
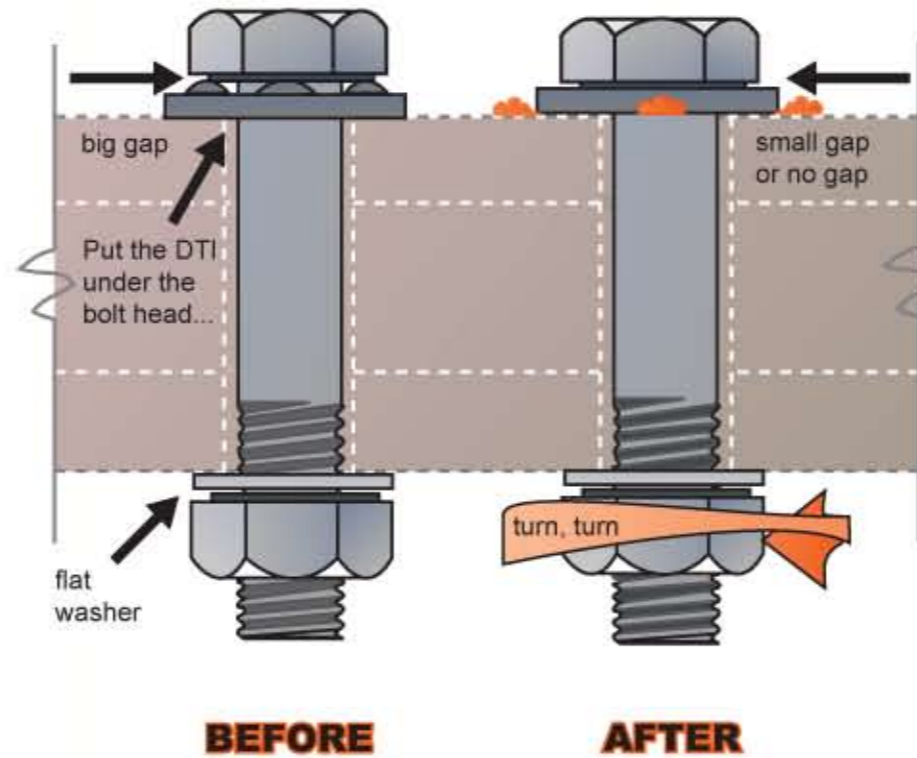
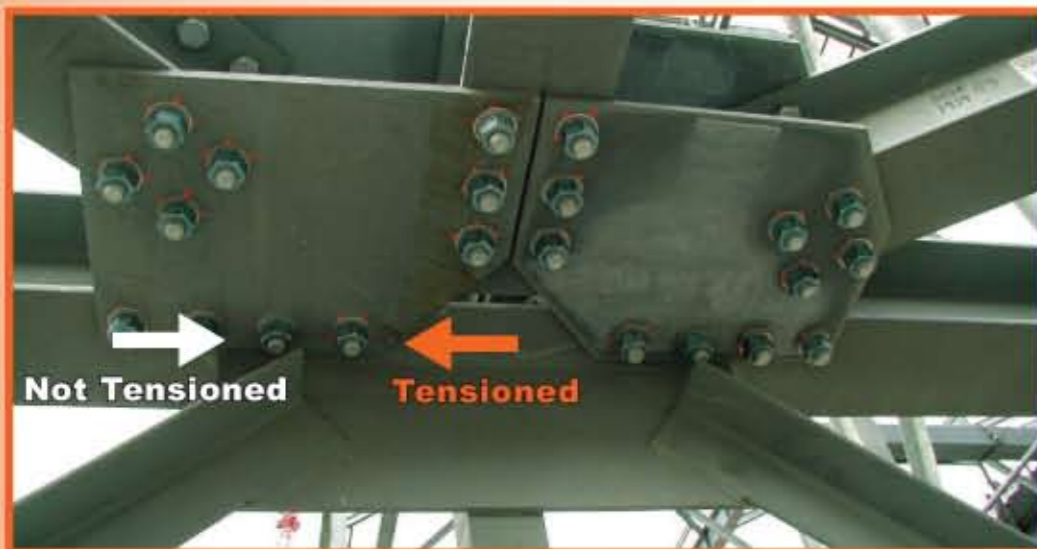

Since 1935
... because quality matters

Orange is good ... SQUIRTER™DTI's

Features

- ✓ Manufactured to ASTM F959M.
- ✓ Conforms to AS4100-1990 15.4.1 (b) Direct-tensioning indication device.
- ✓ Lot trace number on each washer.
- ✓ Test Certificates available online www.hobson.com.au.
- ✓ Visual tension indication by Orange Silicon.
- ✓ Enables efficient & accurate installation of AS1252 assemblies.

Here's what other's think about ... SQUIRTER™DTI's

"We were very pleased with the way the squirter washers performed on our project. The contractor indicated that they made the job go faster and I know that they made inspection quicker and more accurate. We will certainly use them on any future major construction projects.

Charles Little - Inspection Specialists
CenterPoint Energy/TexasGenco

"...Let me tell you. Squirters are light years ahead of any other tightening method. We'd rather use SQUIRTER™ DTI's than any other method.Without squirters, you have to tighten the bolt, call for inspection, maybe retighten, then go on. With squirters, its fast. You just snug the joint, make them squirt enough and then get out of there.....I just look for the orange squirt to know where we've been."

Richard Oliver, a 30 year veteran Babcock & Wilcox Construction employee, speaking from Reliant Energy W.A. Kerr SCR project near Houston